

Breaking the Manufacturing Speed Barrier: Agile Automation That Delivers Tailored Products on a Mass Production Scale



Achieving manufacturing excellence in today's competitive and rapidly evolving market landscape requires both speed and flexibility. Manufacturers and original equipment manufacturers (OEMs) alike must navigate constantly changing production demands and increasing customization requirements while also maintaining the highest quality and efficiency standards. These challenges are further complicated by mounting pressure to transform business operations by producing goods more sustainably and bringing production closer to home.

Traditional manufacturing models built on predictable requirements and fixed processes struggle to address these modern realities. To upgrade production, manufacturers are increasingly turning to digitalization and automation solutions for enhanced efficiency. However, effective automation requires flexible, scalable systems that are tailored to the unique operational requirements of each application.

To overcome these broad industry challenges, the team at the Emerson Bonneville manufacturing facility in the French Alps are applying a forward-thinking methodology to automation. They are making full use of data available from their sensors and devices on the factory floor to optimize and manage their manufacturing process. The facility produces fully configurable AVENTICS™ XV valve systems that are unique to each customer's specifications on a mass production scale. With this data led approach to automation, they can minimize manual interventions and cost while also delivering orders in five days or less.

Here, we'll explore how the Bonneville facility's intelligent automation framework improves its agility and manufacturing capabilities to deliver configurable, cutting-edge solutions that help customers meet their own automation goals. The facility's manufacturing success offers practical insights for organizations seeking similar results in their operations.

The challenges facing modern manufacturers and machine builders

Modern production environments are defined by ever-tighter timelines, increasing complexity and rising expectations for efficiency and sustainable

production. There is a growing imperative to do more with less — less time, waste and often, fewer skilled hands on the floor.

Manufacturers and the OEMs and machine builders that equip them must overcome a range of challenges to meet modern production demands.

- **Shifting demands and increasing customization:** Shorter product cycles and greater expectations for customization all create significant operational challenges. In this environment, flexibility is critical for long-term competitiveness.
- **Speed and quality expectations:** Today, operational efficiency is more than a cost lever; it's a core competitive advantage. The ability to consistently maintain rapid throughput without sacrificing quality or performance is essential to earning customer trust and competing in the modern marketplace.
- **Sustainability and regulatory compliance:** With corporate sustainability commitments and evolving environmental regulations, manufacturers and the upstream OEMs that support them must find ways to reduce overall energy use, minimize waste and optimize resource consumption, all while remaining efficient and competitive, ultimately driving sustainable growth.
- **Reshoring pressures:** Economic and supply chain pressures are mounting for manufacturers to bring production closer to end markets and where they operate. For many companies, this means operating in higher-cost regions where skilled workers are in short supply.

Navigating these complexities requires close collaboration across disciplines, supported by digital tools and workflows that keep communication and decision-making on track throughout design, development and deployment.

Engineering and implementing automation systems to overcome these hurdles requires innovative solutions that simplify processes, streamline integration and scale efficiently.

Applying a data led approach to automation

Emerson's automation approach connects data from devices and sensors on the factory floor to enterprise systems, creating a comprehensive framework for manufacturing intelligence. This integration of digital and physical processes unlocks trapped data, delivers actionable insights, and powers a cohesive, data-driven operation. At the Bonneville facility, this approach is setting new benchmarks for advanced manufacturing and factory automation.

Their automation approach starts at the plant floor with components, like valves and actuators, along with smart devices and sensors that collect data. These connect to edge controllers and analytics software that translate the data into valuable insights that scale in the cloud. This approach brings operational technology (OT) and information technology (IT) together, putting specialists from both areas in closer collaboration to solve plant floor challenges. With real-time visibility and control, teams can solve critical manufacturing challenges, optimize operations and maximize a facility's existing equipment, resources and labor power.

At the foundation of Bonneville's Automation approach is real-time monitoring capabilities powered by advanced software platforms like Movicon™ Pro.Lean™ and Movicon™ Pro.Energy™. These systems provide operators with instant performance metrics, including overall equipment effectiveness (OEE), resource allocation and energy efficiency. Unlike traditional manufacturing environments where performance data is collected retrospectively, Bonneville's operators can identify and address issues as they develop, minimizing their impact on production schedules.

This data-driven approach to manufacturing also enables continuous, step-by-step improvements to processes and equipment. Useful insights into factory performance allow companies to identify areas for improvement, integrate the right technology to address specific challenges and then scale as needed to enhance production.

In addition to the Movicon platform, the operation unifies other core Emerson technologies throughout the facility to create a comprehensive automation ecosystem:

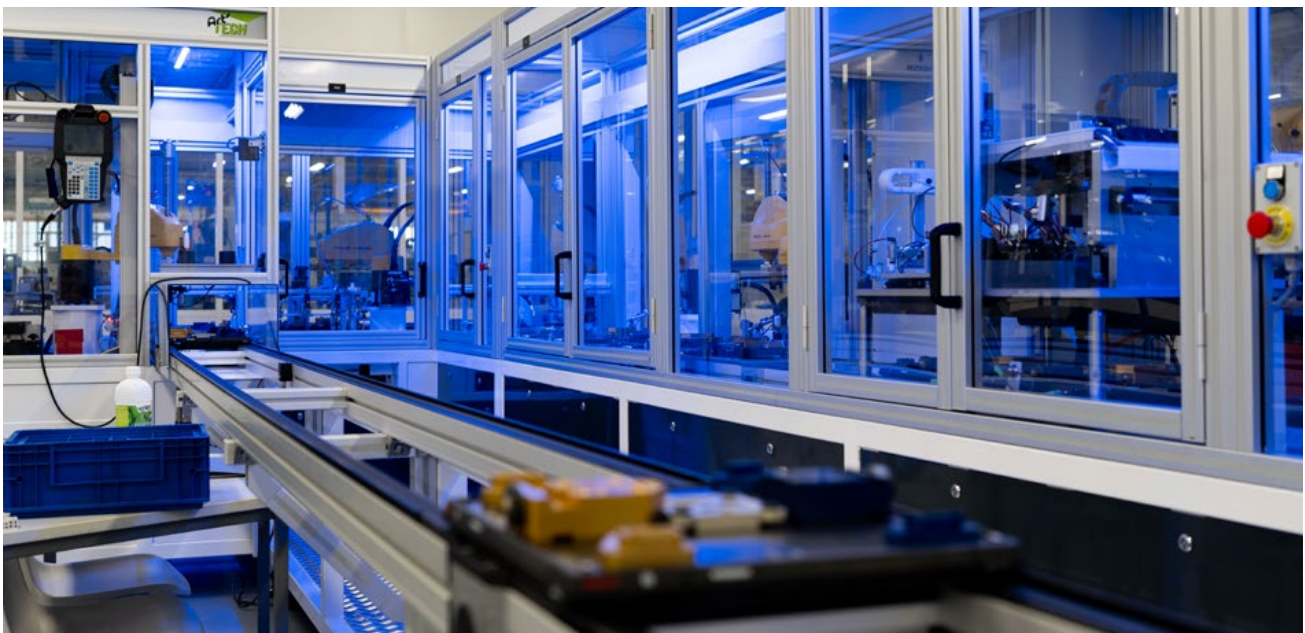

A data led approach simplifies technology integration and streamlines automation projects.

- Fully configurable **AVENTICS pneumatic valve islands** provide precise, reliable pneumatic operation, and **ASCO valves** optimize fluid control in production lines. Grouping pneumatic valves into a single island minimizes assembly and wiring, drastically reducing installation time. And with the wide range of available protocols, these systems are compatible with many PLCs and programming languages.
- **AVENTICS pneumatic cylinders and actuators** power material handling and positioning systems. Configurable for any application, AVENTICS cylinders and actuators bring efficient, reliable and precise performance to automated production lines.
- **AVENTICS AF2 flow monitoring systems** track compressed air usage and other key parameters to identify issues early and enable predictive maintenance. The AF2 sensors help optimize energy consumption associated with compressed air, reduce waste and reduce machine downtime.

A data led approach simplifies technology integration and streamlines automation projects so that companies can take on modern manufacturing challenges. With the right technology, companies can increase efficiency to meet higher production demands; enhance flexibility to support production changes and customization; minimize manual labor and empower teams to support reshoring production; and reduce waste and energy consumption to meet sustainability goals.

Revolutionized manufacturing delivers next-generation valve technology

Powered by the Floor to Cloud approach and its advanced manufacturing capability, Emerson embarked on an ambitious project to rewrite the rules of flexibility and automation when manufacturing its next-generation AVENTICS XV valve platform at the Bonneville facility.

What sets the AVENTICS XV valve series apart is its complete configurability for each order — every AVENTICS XV product is different. The modular platform is designed for interoperability and streamlined integration, enhancing flexibility and scalability with electronics that support a full range of fieldbus protocols and a broad assortment of sizes, options and accessories. Machine builders can specify exact valve combinations and fitting configurations to match their precise operational needs. The options result in about 100 million different configurations.

The challenge for Emerson was to develop manufacturing capabilities that efficiently produce these fully configured products while meeting aggressive lead-time commitments. Using this data led approach, the Bonneville facility was able to automate processes from design to deployment, allowing the team to deliver customized orders in just five days or less.

The facility's fully automated loop for producing the AVENTICS XV valve platform connects customer orders with real-time production, allowing the Bonneville team to produce tailored configurations at mass production speeds and industry-leading delivery times.



At the heart of the operation is a fully automated workflow that transforms customer configurations into finished products. Using the Emerson online configurator, customers can choose the number of valves and fittings, along with their sizes and locations, to create a completely unique valve configuration for their application. The automated process then generates 3D files of the customizable aluminum base, machining instructions for cutting the part and machining simulations to verify the cutting data. Finally, the system sends the verified data to a machining center for final production.

automatically generated. If simulations reveal any issues, the system automatically generates detailed error reports in an email delivered to the operator.

Built on a concept Emerson calls “from e-shop to workshop,” the entire automated loop is digitally coordinated to enable rapid design, production and quality assurance, streamlining every step from order to finished part.

1. Configuration to CAD

When customers complete their valve configuration using the Emerson online configurator, the system automatically generates target files containing all manufacturing specifications and 3D models of the subbase. For each drilling, tapping and milling operation required to create the customer’s unique valve base, the system generates detailed assemblies in CAD software.

2. Automated programming

The CAD assemblies, with every cutting location and operation identified, are then converted into machine-readable programs, commonly called the G-code, using sophisticated post-processing software. This eliminates the need for programmers to manually code tool paths and cutting data for each unique part.

3. Simulation

Before machining begins, simulation software validates every program, checking for potential collisions or errors that could damage equipment or compromise quality. Only programs that pass validation proceed to the production floor.

4. Production execution

Validated programs are automatically deployed to the appropriate machining center through the facility’s distributed numerical control (DNC) system. Machines receive complete programs ready for execution, with all tooling and setup information

**From E-Shop to Workshop
Process Flowchart:**

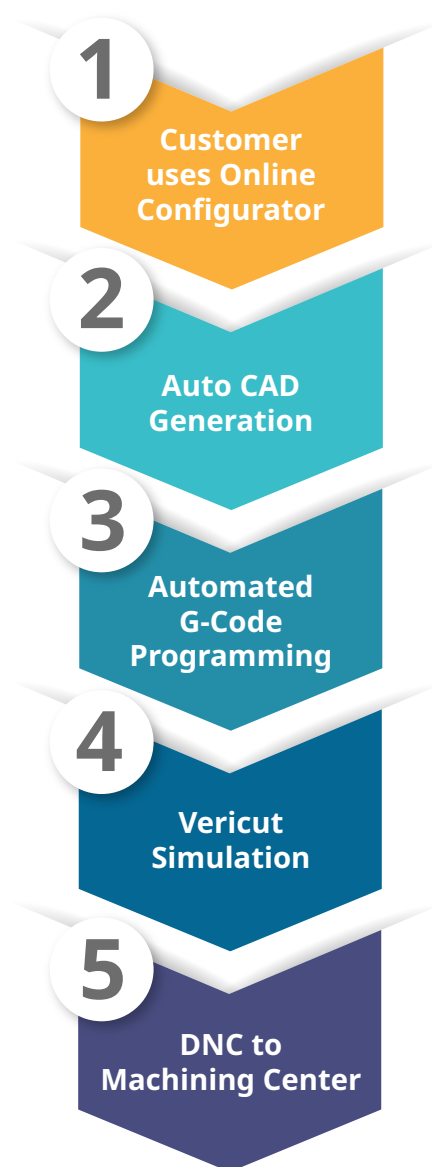

Automation that drives results

The Bonneville facility's holistic approach to automation investment has delivered quantitative and qualitative benefits to its operation. Traditional approaches to mass customization often accept trade-offs between variety and efficiency. Bonneville demonstrates that intelligent automation can eliminate these compromises. Their success provides insights that are applicable across manufacturing industries facing similar customization and speed challenges.

- **Production efficiency**

The facility produces over 100,000 valve configurations annually, with each product representing a uniquely configured design. Traditional manufacturing approaches would require substantial engineering resources to support this level of customization. And by automating the programming and setup process for each AVENTICS XV configuration, Bonneville eliminates 2-4 hours of manual work per product, providing significant cost savings while also improving delivery speed.

- **Lead time performance**

Customer orders from the online configuration tool move from configuration

completion to production readiness in approximately 10 minutes. This dramatic reduction in processing time lets the facility keep to its five-day delivery commitment, even with custom products. The automated workflow also improves reliability, eliminating bottlenecks associated with engineering review, programming and production setup.

- **Quality and consistency**

Automated programming, simulation and validation help eliminate human errors that can compromise product quality or cause downtime. The system's ability to detect potential issues before they occur can reduce scrap and enable data-driven quality assurance for each unique product.

- **Operational flexibility**

The facility's automation architecture supports scalable flexibility to meet demand fluctuations. Additional capacity can be activated quickly without requiring proportional increases in skilled labor, enabling lean and agile operations that support business growth.

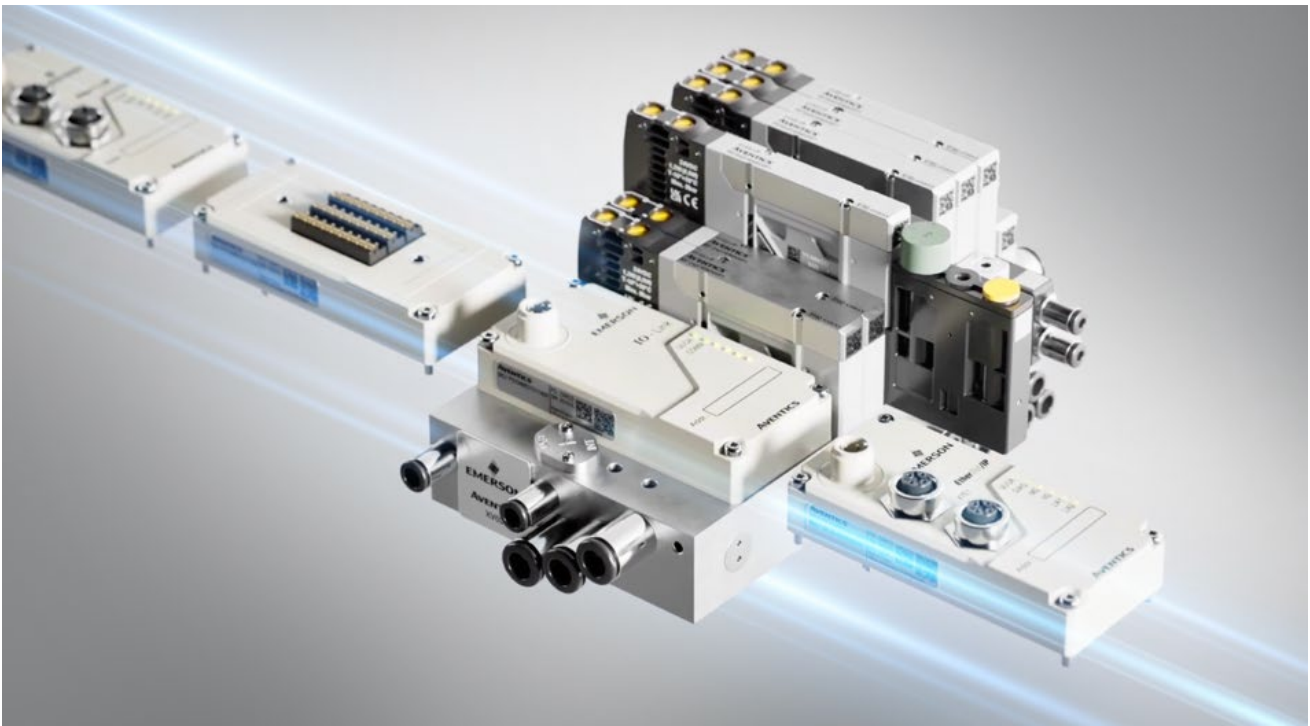

The future of flexible manufacturing

As manufacturing continues to evolve toward increased customization, higher production demands and a greater need for efficiency on every level, manufacturers and the machine builders who supply them need automation solutions that can support continuous improvement. The Emerson Bonneville facility's approach to automation offers a potential model for achieving unprecedented levels of manufacturing flexibility without sacrificing speed, quality or cost effectiveness.

Success in modern manufacturing requires more than advanced technology — it takes a fundamental rethinking of how organizations integrate systems, processes and people to deliver value. The Bonneville facility shows that a data led approach to automation can help bring these factors together to improve manufacturing agility and efficiency, pointing the way to a more flexible future for manufacturing.

Maximize performance and unleash potential

There is a misconception that automation is a huge undertaking that must be done all at once. However, the data led approach is highly scalable and flexible, allowing companies of any size, type or stage of digital maturity to start small and scale up.

Partner with Emerson to take the first step and gain access to one of the industry's most comprehensive automation portfolios and extensive engineering expertise.

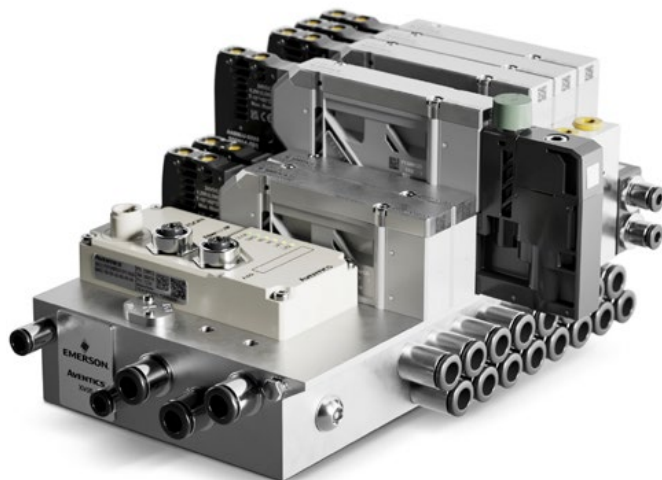

Customizable to application requirements

- Available in two sizes, the variable platform is scalable across electrical control options, pneumatic connectivity and accessories.
- Industry-leading online configuration tools accelerate and simplify the design process, offering real-time 3D illustration and immediate pricing.

Flexibility to meet application needs

- The Series XV is compatible with a wide range of accessories, including pressure regulators, shut-off valves, flow-speed modules and pressure-supply modules.

Gain greater automation flexibility and superior pneumatic performance

With up to 100 million possible valve system configurations, the **AVENTICS™ Series XV** is a new high-flow pneumatic valve platform that provides machine builders an unparalleled level of flexibility and scalability across industries and applications.



- Extensive connectivity to communication platforms, including Profinet, Ethernet/IP, EtherCAT, Powerlink, Modbus TCP, IO-Link and AS-Interface (ASi), simplifies integration.
- Universal threads support regional standards and global availability.

Robust and compact design

- Compact dimensions with pneumatic connections on the front, top and bottom of the module better fit into tight cabinet configurations.
- AVENTICS core valve technology, including metal threads and an aluminium base plate, increases machine uptime and reduces maintenance.
- Excellent flow-to-volume ratio improves pneumatic system efficiency and compressed air utilization
 - XV03 provides flow volumes up to 350 NL/min
 - XV05 provides flow volumes up to 1000 NL/min

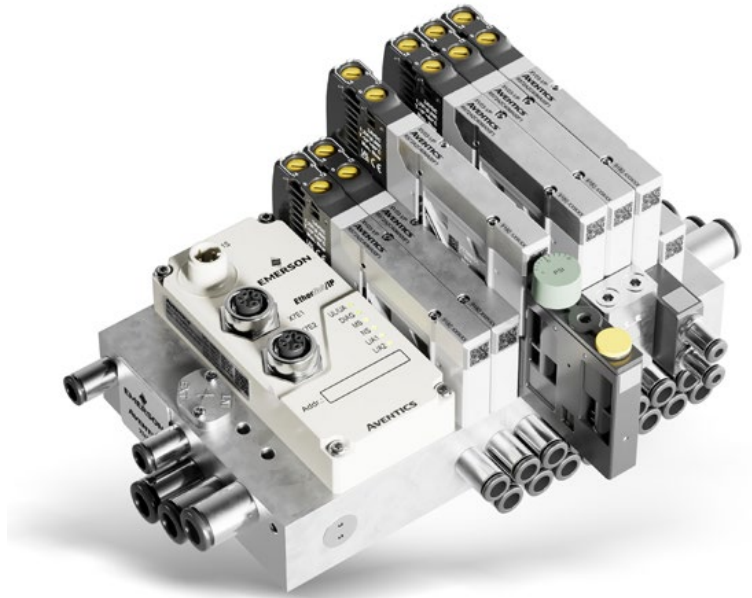

Robotics plays a critical role in operations at Bonneville. With a **robot density of 32%** — **equalling one robot for every three human operators** — Bonneville operates at more than 20 times the global manufacturing average for robot density (1.4%).

To learn more visit
www.Emerson.com/Aventics



www.Emerson.com/contactus

